



## UVTOP335

- Deep Ultraviolet Light Emission Source
- 340 nm, 240-400  $\mu\text{W}$
- TO metal can with  $\text{SiO}_2$  glass lens
-  Blood Gas Measurements



### Description

**UVTOP335** is a series of **AlGaIn** based deep UV-LEDs with a typical peak wavelength of **340nm** and optical output power of **240-400  $\mu\text{W}$** . It comes in hermetically sealed TO39 or TO18 metal can package with ball lens, hemispherical lens, or flat glass window configuration. **UVTOP335** is widely used for **blood gas measurements, nitrogen urea measurements**, and UV-curing applications

### Maximum Ratings ( $T_{\text{CASE}} = 25^\circ\text{C}$ )

Parameter	Symbol	Values		Unit
		Min.	Max.	
Power Dissipation, DC	$P_D$		180	mW
Forward Current, DC	$I_F$		30	mA
Pulsed Current (1% duty cycle, 1kHz)	$I_{FP}$		200	mA
Reverse Voltage	$U_R$	-6		V
Operating Temperature	$T_{opr}$	-30	+55	$^\circ\text{C}$
Storage Temperature	$T_{stg}$	-30	+100	$^\circ\text{C}$
Soldering Temperature (max. 5s)	$T_{sol}$		+190	$^\circ\text{C}$

### General Characteristics ( $T_{\text{CASE}} = 25^\circ\text{C}$ , $I_F = 20\text{mA}$ )

Parameter	Symbol	Values			Unit
		Min.*	Typ.*	Max.*	
Peak Wavelength	$\lambda_P$	335	340	345	nm
Half Width (FWHM)	$\Delta\lambda$		15	20	nm
Forward Voltage	$U_F$		5.0	6.2	V

\*wavelength measurement tolerance:  $\pm 2$  nm, forward voltage measurement tolerance:  $\pm 2$  %

### Electro-Optical Characteristics ( $T_{\text{CASE}} = 25^\circ\text{C}$ , $I_F = 20\text{mA}$ )

Part Number	Package	Window	Optical Power $P_{\text{OUT}}$ ( $\mu\text{W}$ )		View. Angle $2\theta_{1/2}$ ( $^\circ$ ) Typ.
			Min.*	Typ.*	
UVTOP335-FW-TO39	TO-39	Flat Window	240	400	120
UVTOP335-TFW-TO39		Flat Window	120	200	120
UVTOP335-TFWR-TO39		Flat Window	165	275	120
UVTOP335-HL-TO39		Hemisph. Lens	180	300	7
UVTOP335-BL-TO39		Ball Lens	240	400	7
UVTOP335-FW-TO18	TO-18	Flat Window	210	350	120
UVTOP335-BL-TO18		Ball Lens	210	350	10

\*output power measurement tolerance:  $\pm 10$  %

 **Open Can version (TO18 or TO39, no cap, no window) available on request**



## Performance Characteristics

### Normalized output power vs. Wavelength

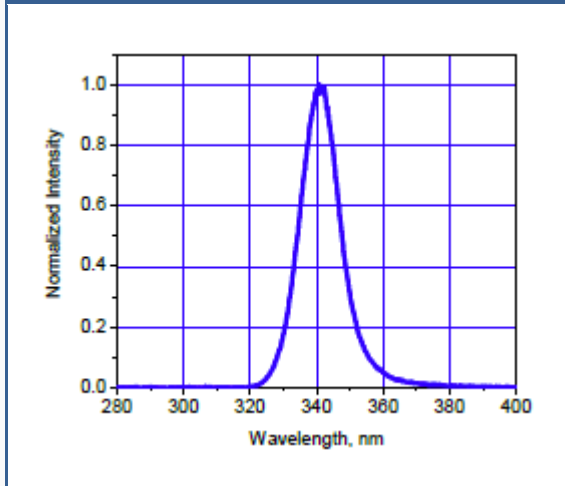

### Peak Wavelength vs. Forward Current

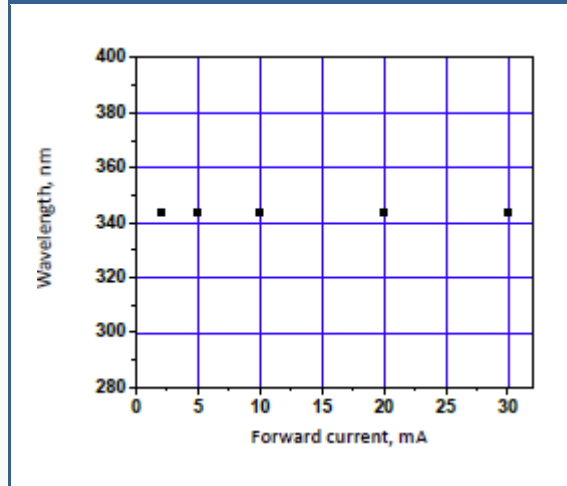

### Forward Voltage vs. Forward Current

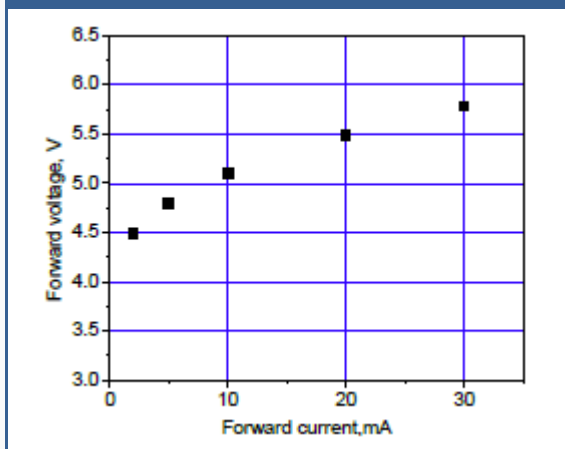

### Output Power vs. Forward Current

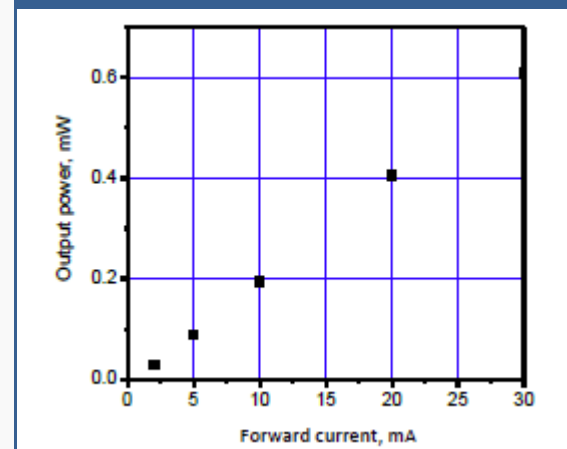

### Normalized Output Power vs. Temperature

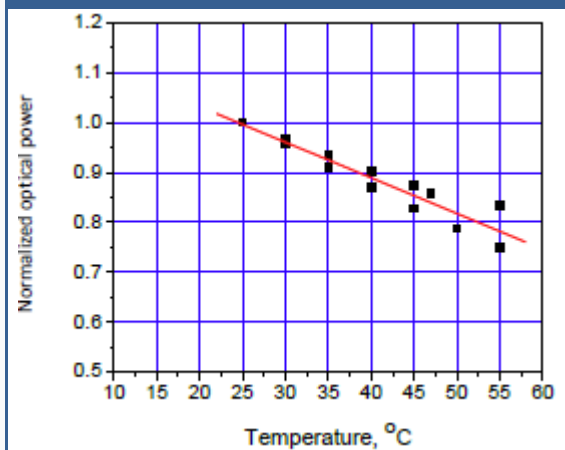

### Normalized Forward Voltage vs. Temperature

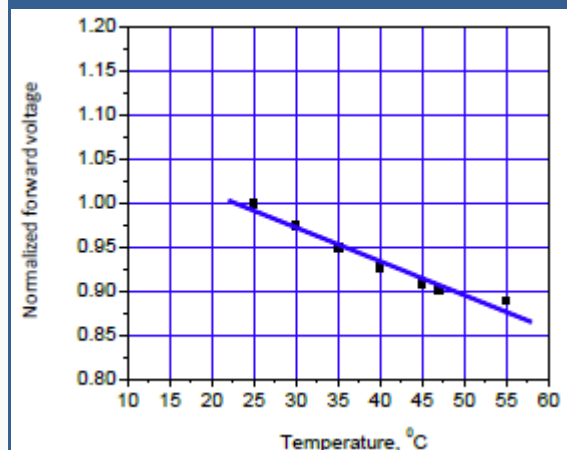



## Outline Dimensions

### TO-39 Flat Window

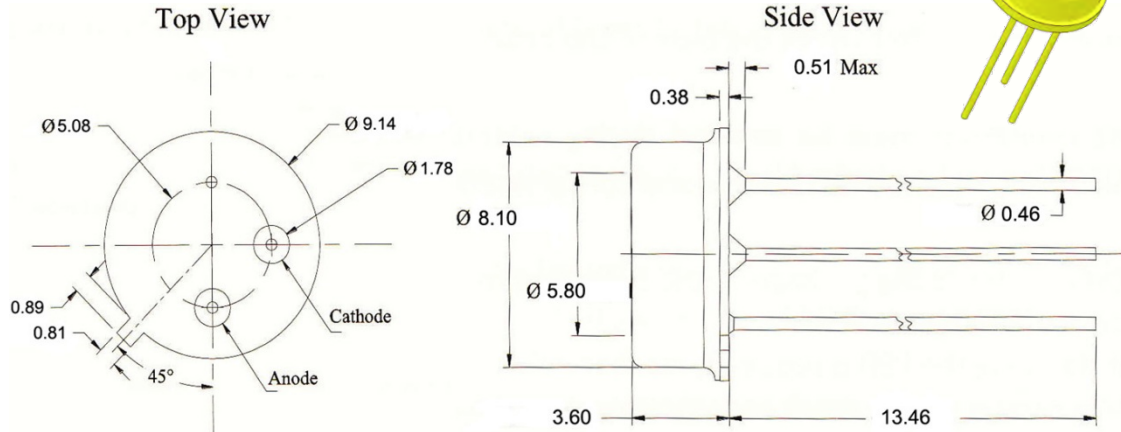

All dimensions in mm

### TO-39 Hemispherical Lens

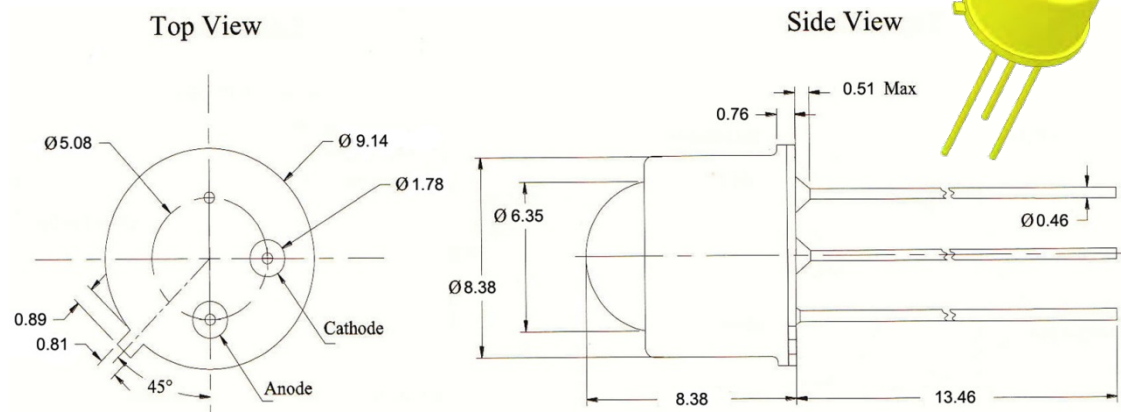

All dimensions in mm

### TO-39 Ball Lens

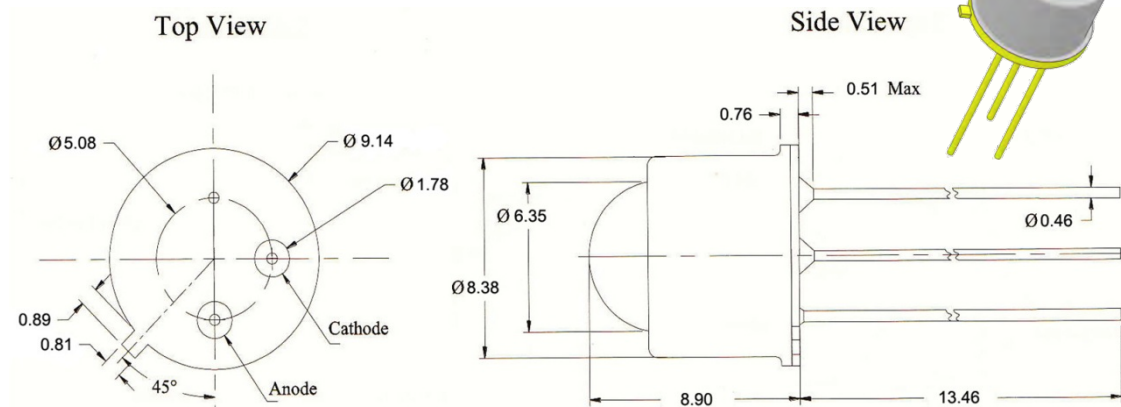

All dimensions in mm



## Outline Dimensions

### TO-39 Tall Flat Window & Tall Flat Window w. Reflector

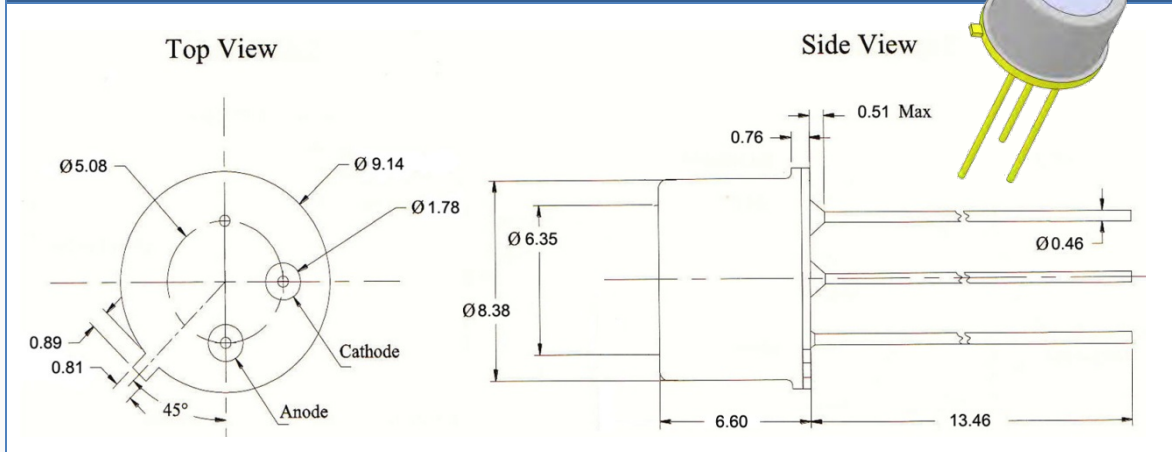

All dimensions in mm

### TO-18 Flat Window

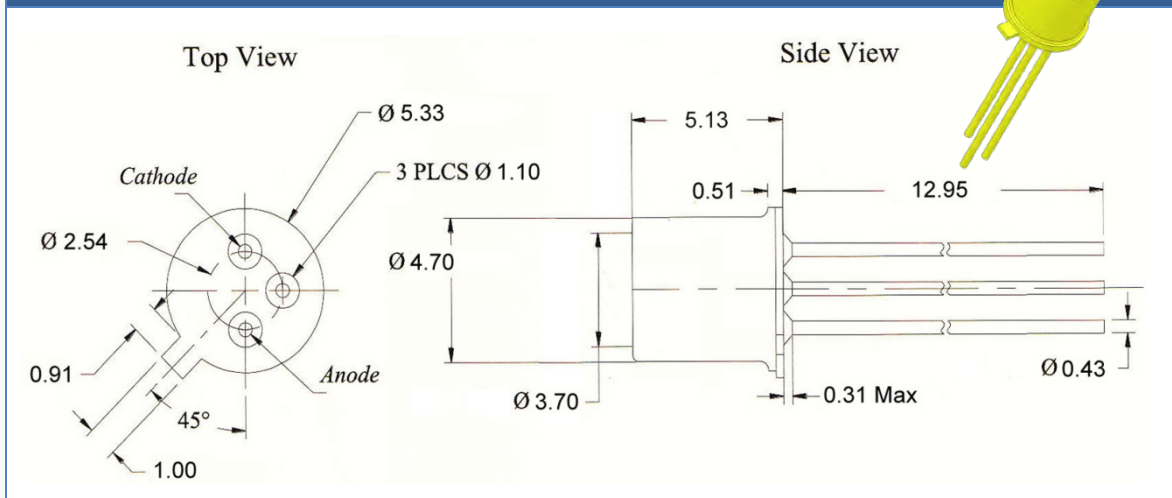

All dimensions in mm

### TO-18 Ball Lens

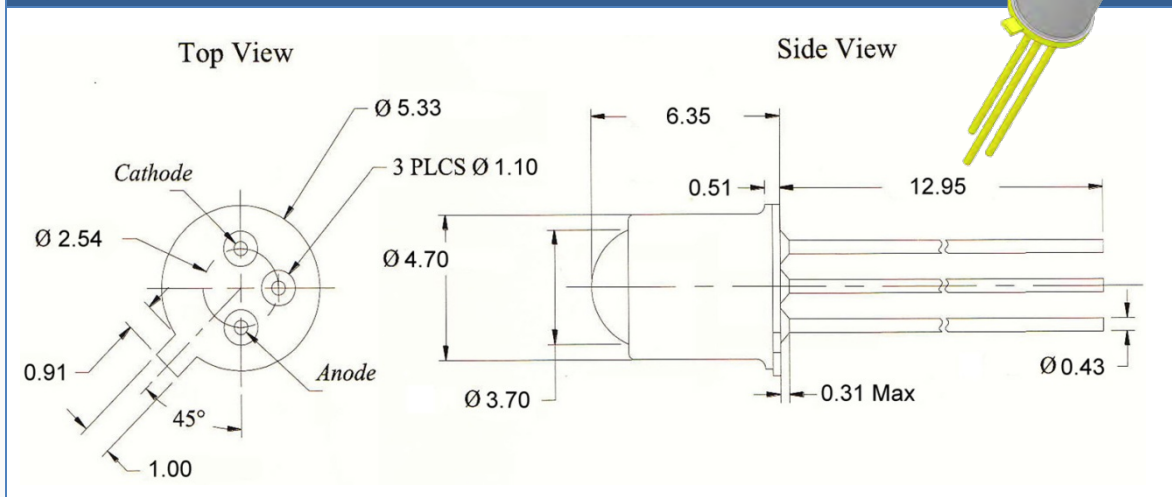

All dimensions in mm



## Device Materials

Part	Material
Header	Fe-Ni alloy, plated Ni-Au
Leads	Fe-Ni alloy, plated Ni-Au
Lens	SiO <sub>2</sub>
Bonding Wires	Au

## Emission Characteristics

### Flat Window

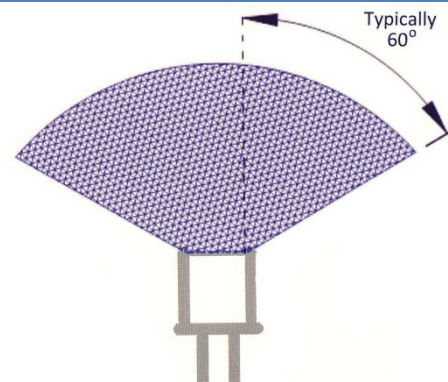
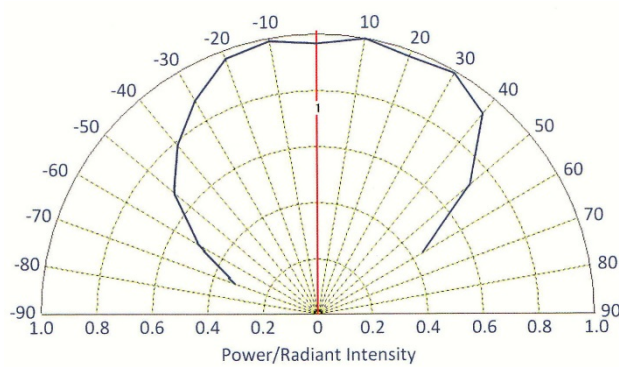

### Hemispherical Lens

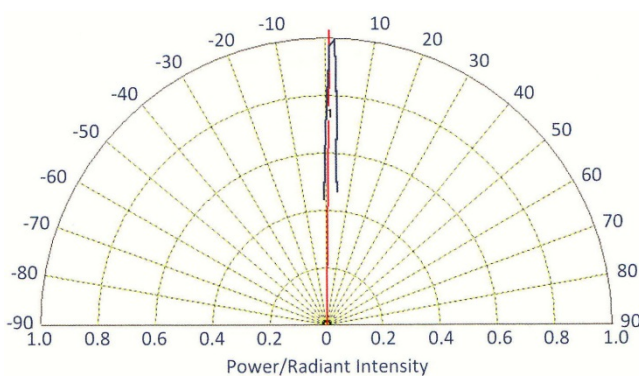

### Ball Lens

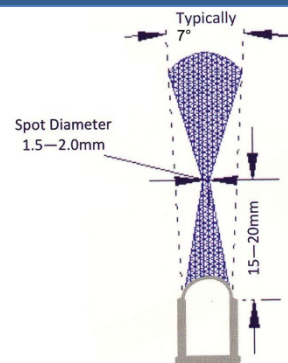
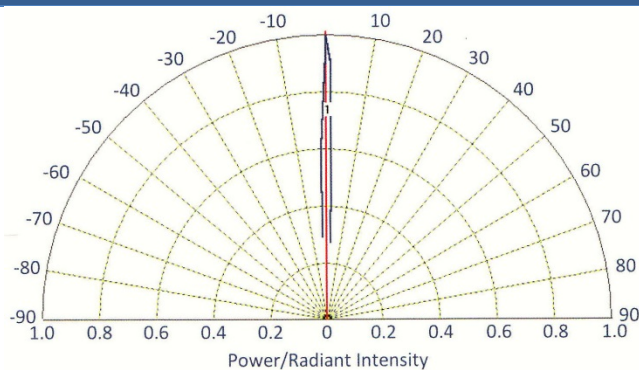



## Precautions

### Soldering:

- Do avoid overheating of the LED
- Do avoid electrostatic discharge (ESD)
- Do avoid mechanical stress, shock, and vibration
- Do only use non-corrosive flux.
- Do only solder the leads. Soldering of header or cap will damage the LED
- Do only cut the leads at room temperature with an ESD protected tool
- Do not solder closer than 3 mm from base of the header
- Do form leads prior to soldering
- Do not impose mechanical stress on the header when forming the leads
- Do not apply current to the LED until it has cooled down to room temperature after soldering

### Recommended soldering conditions:

dip soldering		hand soldering	
pre-heat time	max 30 s	soldering time	max 5 s
dipping time	max 5 s		
solder bath temperature	max 190 °C	solder temperature	max 190 °C

Above table specifies the maximum allowed duration and temperature during soldering. It is strongly advised to perform soldering at the shortest time and lowest temperature possible.

### Cleaning:

**Cleaning with isopropyl alcohol, propanol, or ethyl alcohol is recommended**

DO NOT USE acetone, chloroform, trichloroethylene, or MKS

DO NOT USE ultrasonic cleaners

### Static Electricity:

**UVTOP are sensitive to electrostatic discharge (ESD).** Precautions against ESD must be taken when handling or operating these LEDs. Surge voltage or electrostatic discharge can result in complete failure of the device.

### UV-Radiation:

During operation these LEDs do emit **high intensity ultraviolet light**, which is hazardous to skin and eyes, and may cause cancer. Do avoid exposure to the emitted UV light. **Protective glasses are recommended.** It is further advised to attach a warning label on products/systems that do utilize UV-LEDs:



### Operation:

**Do only operate UVTOP LEDs with a current source.**

Running these LEDs from a voltage source *will* result in complete failure of the device.

Current of a LED is an exponential function of the voltage across it. Usage of current regulated drive circuits is mandatory